



Magnetic Integrated Technology

承康科技

產品規格書 **PRODUCT SPECIFICATION**

檔案號 FILE NO	KEM2500D-14 Ver2.1
日期 DATE	2020/8/6

項次 ITEM NO	機型 MODEL	客戶料號 CUSTOMER P/N
1	KEM2500D-14	
2		

經理 MANAGER	業務 MARKETING	工程 ENG	品保 QA

客戶承認 CUSTOMER APPROVAL		

機型 MODEL	名稱 PRODUCT
KEM2500D-14	2500 PPR 增量型差分編碼器 INCREMENTAL DIFFERENTIAL ENCODER

1. 外型尺寸 OUTLINE DIMENSIONS

CABLE LENGTH: 500mm °

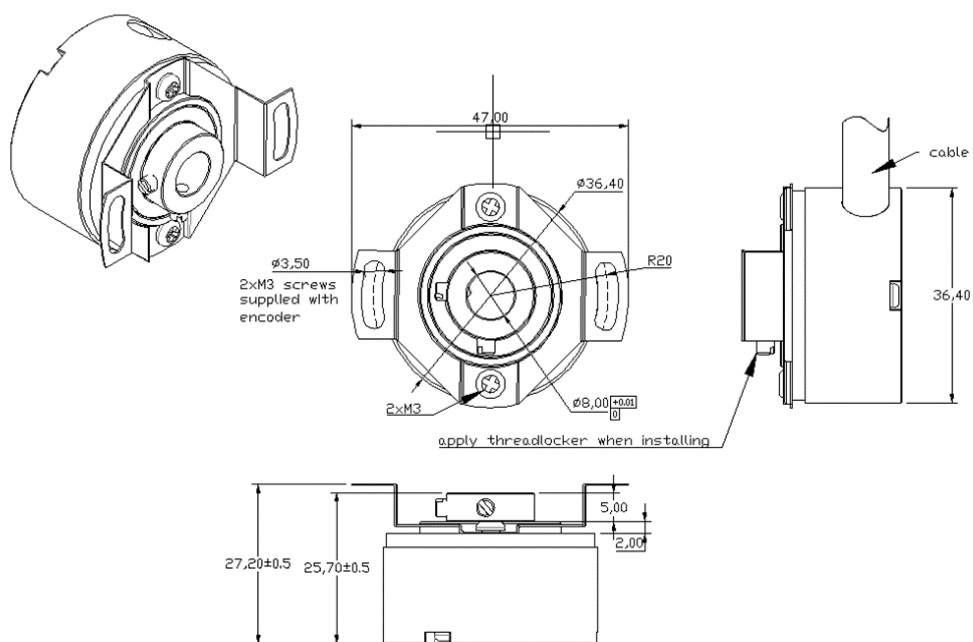

1-1. ENCODER HOLLOW SHAFT & MOTOR SHAFT INSTALLATION

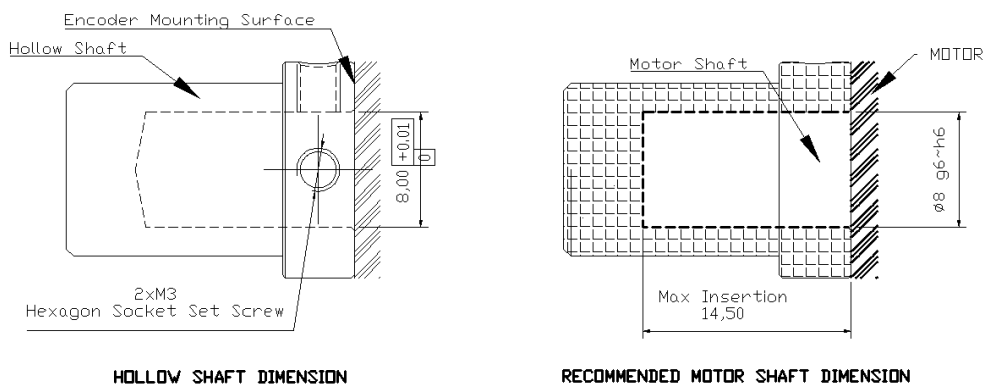

1-2. ENCODER 9/6-PIN FEMALE CONNECTORS

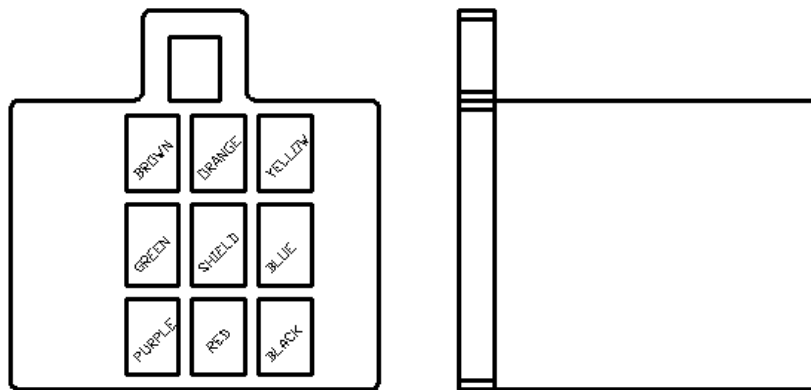
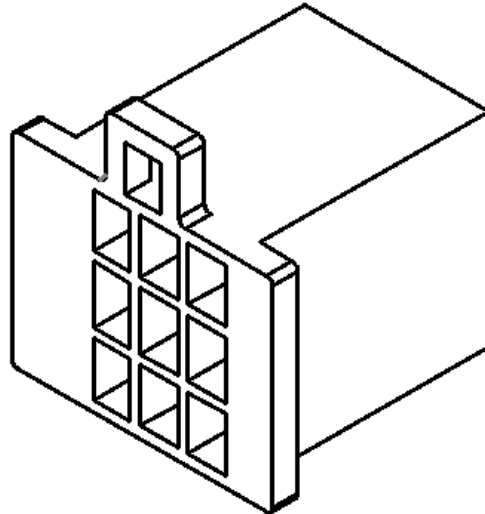

編號	線色 Color	代碼 Code	備注 Note
1	棕 Brown	A+	9-PIN
2	橙 Orange	A-	9-PIN
3	黃 Yellow	B+	9-PIN
4	綠 Green	B-	9-PIN
	屏蔽 Shield		
5	藍 Blue	Z+	9-PIN
6	紫 Purple	Z-	9-PIN
13	紅 Red	DC5V	9-PIN
14	黑 Black	GND	9-PIN

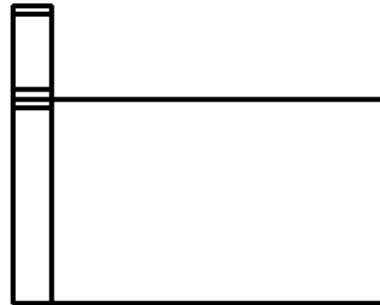
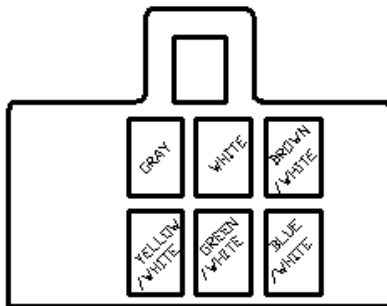
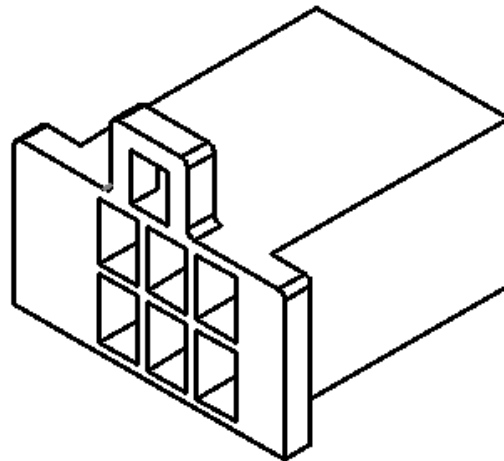

編號	線色 Color	代碼 Code	備注 Note
7	灰 Gray	U+	6-PIN
8	白 White	U-	6-PIN
9	棕/白 Brown/White	V+	6-PIN
10	黃/白 Yellow/White	V-	6-PIN
11	綠/白 Green/White	W+	6-PIN
12	藍/白 Blue/White	W-	6-PIN

2. 接線說明 WIRING DESCRIPTION

Cable Specification: Shielded 14-AWG#26 wire cable.

500mm total length.

編號	線色 Color	功能	代碼	備注
1	棕 Brown	編碼器 A+通道	A+	9-PIN
2	橙 Orange	編碼器 A-通道	A-	9-PIN
3	黃 Yellow	編碼器 B+通道	B+	9-PIN
4	綠 Green	編碼器 B-通道	B-	9-PIN
5	藍 Blue	編碼器 Z+通道	Z+	9-PIN
6	紫 Purple	編碼器 Z-通道	Z-	9-PIN
7	灰 Gray	U/ BLDC Motor	U+	6-PIN
8	白 White	U-/ BLDC Motor	U-	6-PIN
9	棕/白 Brown/White	V / BLDC Motor	V+	6-PIN
10	黃/白 Yellow/White	V-/ BLDC Motor	V-	6-PIN
11	綠/白 Green/White	W/ BLDC Motor	W+	6-PIN
12	藍/白 Blue/White	W-/ BLDC Motor	W-	6-PIN
13	紅 Red	電源+	DC5V	9-PIN
14	黑 Black	電源-	GND	接地

3. 適用範圍

APPLICATION SCOPE

本產品適用於各種工業電子產品如安防監控設備、電動輪椅、運動器材等；

This encoder is suitable for industrial electronic products such as security monitoring equipment, server system etc.

4. 機型

MODEL & DESCRIPTION

KEM2500D-14

2500 PPR Incremental Encoder

5. 外觀 APPEARANCE		外觀應無明顯損傷，如有疑義以限度樣品為準； There shall be no remarkable damage in the visual inspection. Products shall be judged by boundary samples if there are any doubts.	
6. 尺寸 DIMENSIONS		參照 1. 外型尺寸圖 REFER TO CLAUSE 1 OUTLINE DIMENSIONS	
7. 最大額定 MAX RATING			
項次 NO.	項目 ITEM	測試方法及條件 TESTING METHOD AND CONDITION	規格 SPECIFICATION
7.1	工作溫度範圍 Operating Temp		-40 ~ +85°C
7.2	儲存溫度範圍 Storage Temp		-40 ~ +105°C
7.3	工作電壓 Operating Voltage		5.0 VDC
7.4			
8. 規格 SPECIFICATION			
8.1	旋轉方式 Rotational Type	電機驅動 Motor Shaft Operating	Φ8 Shaft
8.2	旋轉角度 Rotation Angle		Continuous
8.3	連續電氣角度 Electrical Continuity Angle		Continuous
8.4	理論電氣角度 Theoretical Electrical Angle		Continuous
8.5	額定功率 Rated Power		0.1W @ Vdd=6V
8.6	操作扭力 Operation Torque		N/A

8.7	輸出信號 Output Signal	十二路差分 12-Phase differential	A+, B+, Z+; A-, B-, Z- U+, V+, W+; U-, V-, W-
8.8	噪音 Noise		N/A
8.9	工作電流 Operating Current	@Vdd=6.0V	Max: <20mA Typical: <10mA
8.10	最高轉速 Output Frequency	RPM	≤10K
8.11	輸出延時 Output Propagation		≤5 uS
8.12	輸出數字信號 Output Digital Voltage	Push-pull (Iout=2mA)	HIGH: $V_{OH} \geq 4.8V$ LOW: $V_{OL} \leq 0.1V$
9. 可靠性 RELIABILITY			
9.1	壽命 Cycle Life		Infinite
9.2	重量 Weight		150g±20g
9.3	耐熱性 High Temp	96 hours@80±2°C	Output variation <0.2%;
9.4	耐寒性 Low Temp	96 hours@-30±2°C	Output variation <0.2%;
9.5	耐濕性 Humid	96 hours@60±2°C, 90~95% RH	Output variation <0.1%;
10. 環境 ENVIRONMENTAL			
		ROHS	Compliant
10.1	ESD; HUMAN	MIL-STD-883G Method 3015.7	(±)1000V ~ 4000V, Step : (±)500V
10.2	ESD; MACHINE	JEDEC EIA/JESD22-A115	(±)100V ~ 300V, Step : (±)50V

2. Appendix: The Installation

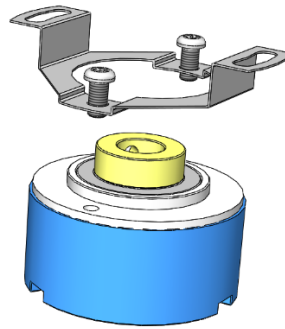

KEM encoder is usually using hollow shaft to allow motor shaft directly insert into the hollow, it shall be mounted by a flexible mounting plate as shown in figure above. Make sure to fix the shaft in that the mounting plate will not cause burden the ball bearing to the encoder and will not cause damage to the mounting plate.

Encoders are usually installed at the rear end of motor, shown as below pictures. The 8mm dia. motor shaft is standard and 6mm is optional. Insert the motor rear shaft into encoder's hollow shaft for about 12mm depth, tighten the encoder's flexible mounting bracket firmly onto motor rear end by two M3 screws.

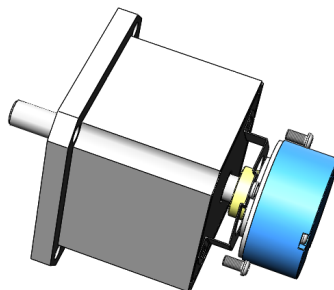

Do not couple the encoder shaft with the rigid driving connector, as the ball bearing of the encoder may be damaged due to excessive load.

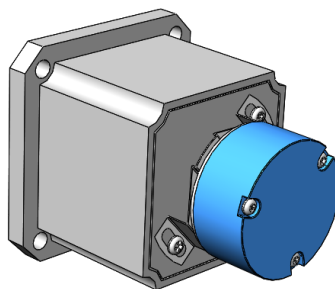

承康科技 增量型永磁編碼器系列

A. KEM2500D-14 增量型差分編碼器說明

KEM2500D-14為十進制增量型差分編碼器，可360度順時針和反時針連續旋轉計數，經常用於伺服電機來反饋電機旋轉角度、速度、轉向等訊息。

KEM2500D-14同時輸出A,B,Z (+)、A,B,Z (-)、U,V,W (+)、U,V,W (-) 共十二路脈衝信號。需要增加測量的精度時，可以採用4倍頻方式，即分別對A、B相波形的上升沿和下降沿（edge）計數，分辨率便可以提高4倍，即每線0.036°的角位移量，但是被測信號的最高頻率相應降低。

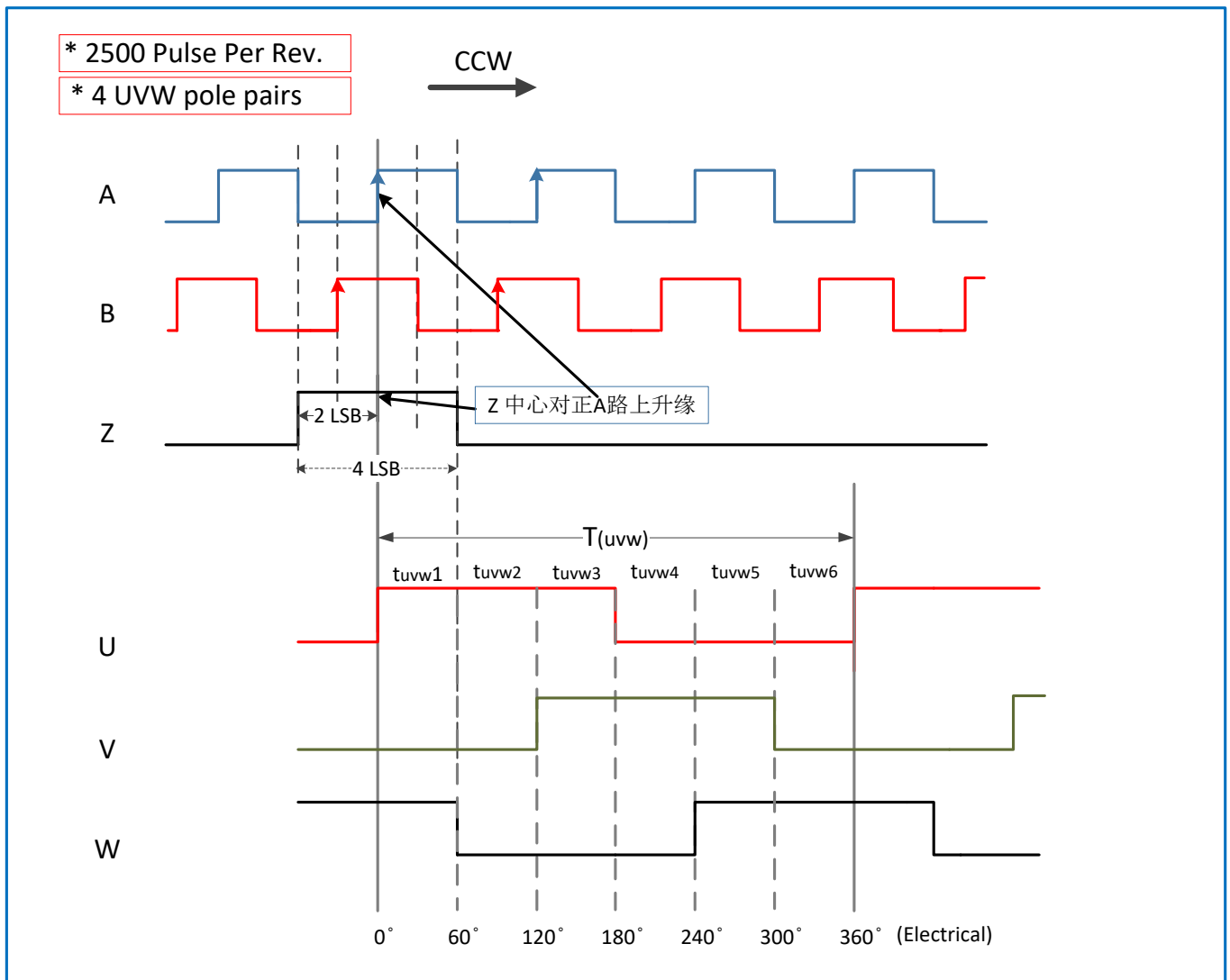

KEM2500D-14 型增量編碼器最高轉速 10000 RPM，可檢測高速電機旋轉角度。

ABZ 差分輸出：

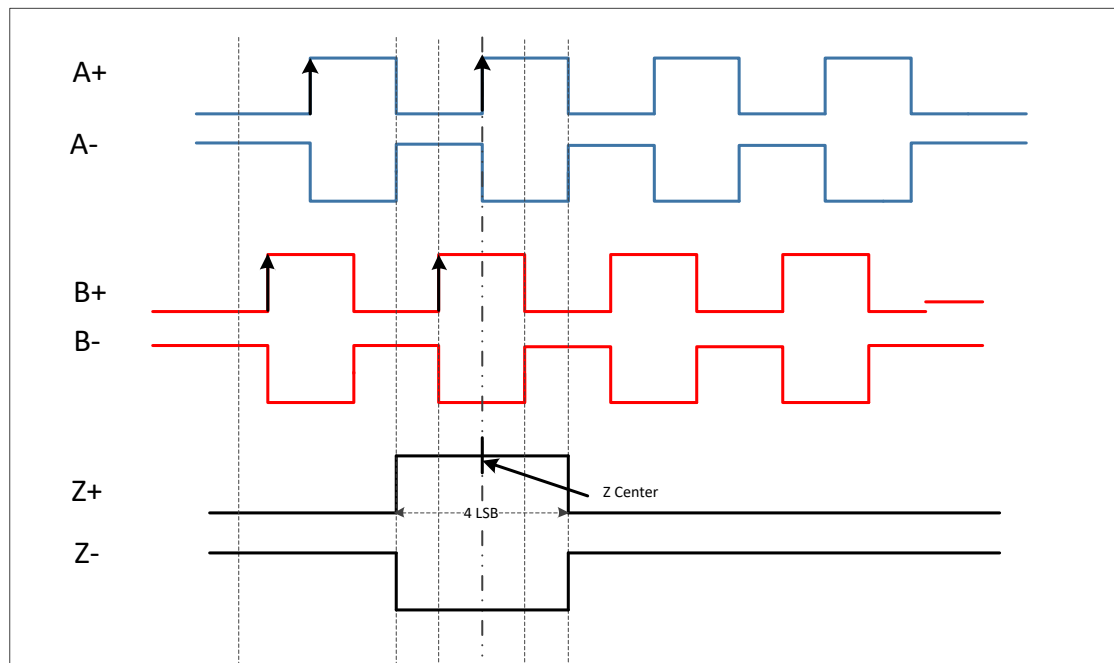

UVW 差分輸出：

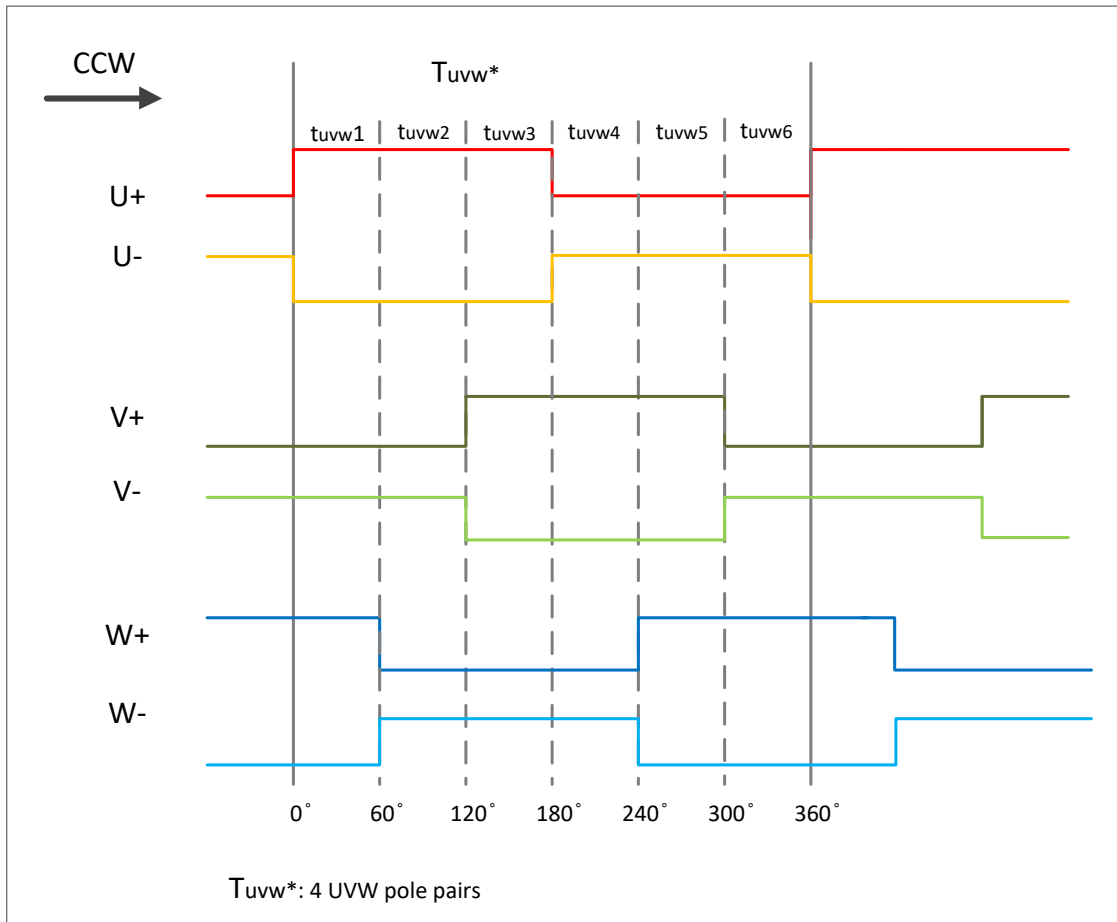

B. 脈衝和旋轉方向判定

脈衝週期 (T):

一個完整的脈衝週期 (T) 如下圖所示，一週期 (T) 等於 360° 電氣角度。

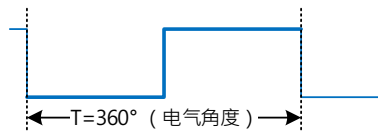

雙相正交：

下圖為雙相 (A、B 通道) 增量型編碼器的輸出脈衝信號，很明顯可看出 B 相滯後 A 相四分之一週期，即 90° 的電氣角度。這就是所謂的雙相正交編碼器。使用 A/B 相編碼器時，高速計數器應選 A/B 相正交計數器模式，可以實現在正轉時加計數，反轉時減計數。

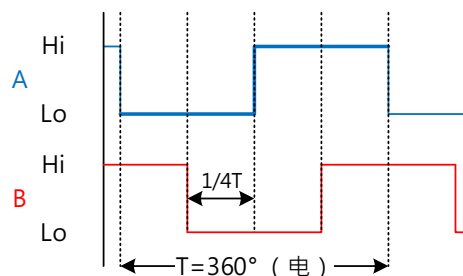

KEM 增量式編碼器除了有 A/B 雙通道增量式編碼器的輸出脈衝外，另外還有一個每轉 1 圈輸出 1 個脈衝的信號的 Z 相零位脈衝或索引脈衝通道，用來做為系統清零信號或坐標原點，以減少測量的累積誤差。

旋轉方向判定：

A/B 雙相編碼器是輸出相位差為 90° 的兩組脈衝序列。正轉(CW)和反轉(CCW)時兩路脈衝的超前、滯後關係剛好相反。正轉時高(Hi)反轉時低 (Lo)。由下圖可知，B 相脈衝的上升沿上，正轉和反轉時 A 相脈衝的電平高低剛好相反。因此使用 A/B 相編碼器時，MCU 或 PLC 可容易的識別出旋轉的方向。

應用時，A 相和 B 相分別連接到 MCU (PLC 亦同) 的兩個輸入端，當 MCU 偵測到 B 相由 Lo 變成 Hi 的上升緣時，只需檢查 A 相的值便可判定編碼器此時的旋轉方向。

A 相為 Hi : 代表順時針 (CW) 旋轉

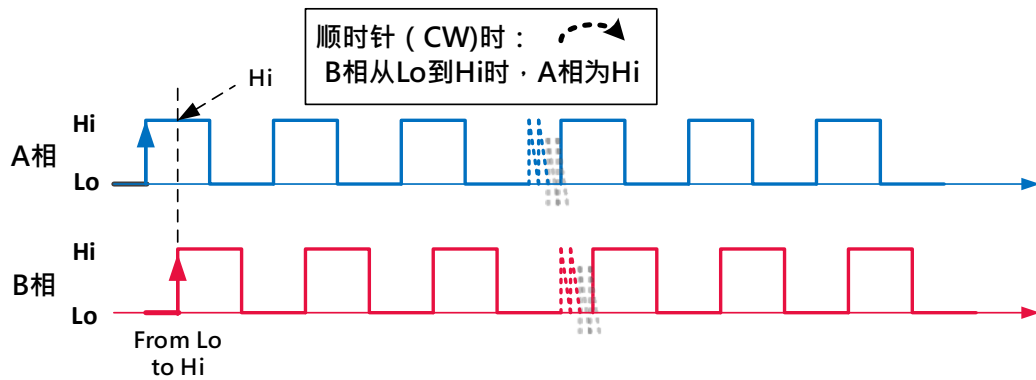

A 相為 Lo : 代表逆時針 (CCW) 旋轉

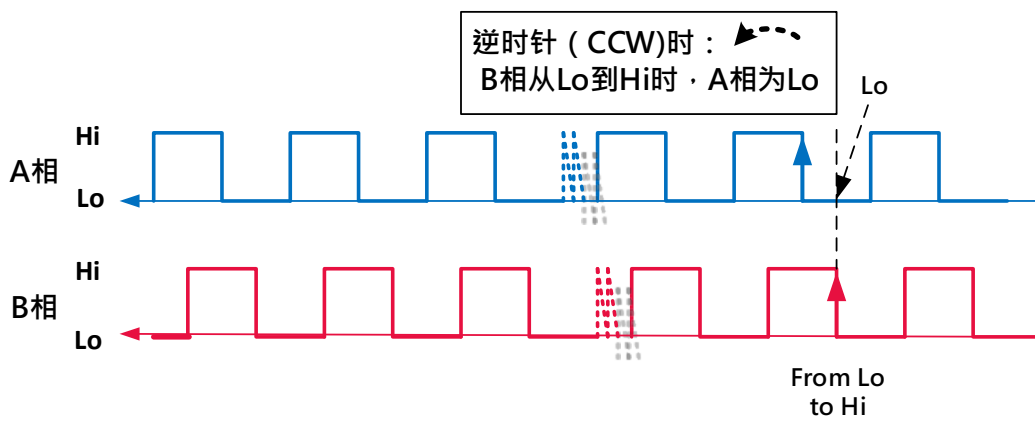

C. 安裝方式

KEM編碼器可安裝於電機後軸，電機後蓋內部或外部，編碼器模組安裝在靠近馬達後蓋處，而磁鐵則安裝在馬達軸心後端隨馬達轉動，磁通量及磁場的變化作用於編碼器模組上使編碼器產生輸出信號。下圖所示為安裝在後蓋外部，若電機內部有合適的空間，則裝在後蓋內側。

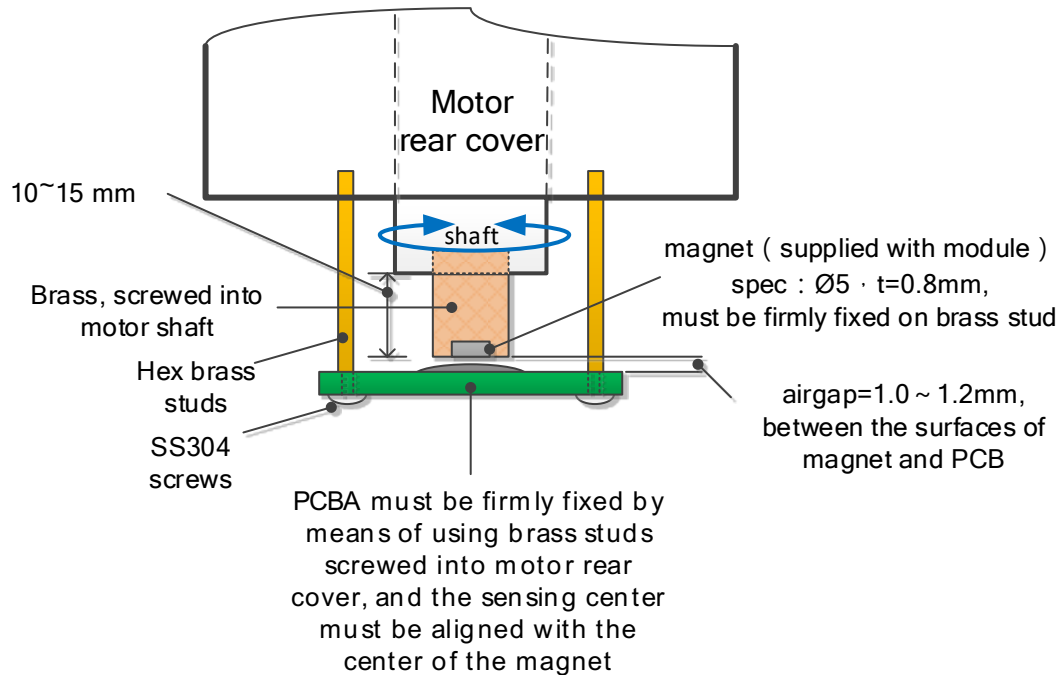

Copy Rights and Disclaimer

1. This document may not be reproduced or duplicated, in any form, in whole or in part without prior written consent of MIT. Copyrights © 2020, MIT Incorporated.
2. MIT reserves the right to make changes to the information published in this document at anytime without notice.
3. MIT's products are limited for use in normal commercial applications. MIT's products are not to be used in any device or system, including but not limited to medical life support equipment and system.

For the latest version of this document, please visit our website: www.chengkangtech.com